



European Technical Assessment + Evaluation report

ETA 25/0618 of 30/06/2026

I General Part

Technical Assessment Body issuing the ETA

Eurofins Expert Services Oy

Trade name of the construction product

VMG Technics Angle Brackets

Product family to which the construction product belongs

Three-dimensional nailing plates

Manufacturer

VMG Technics, UAB

Pramones st. 14, Dirvupiai
92498 Klaipedos dist.
Lithuania

<https://vmg-technics.eu/>

Manufacturing plant

VMG Technics, UAB
Pramones st. 14, Dirvupiai
92498 Klaipedos dist.
Lithuania

This European Technical Assessment contains

27 pages including 3 Annexes which form an integral part of this assessment

This European Technical Assessment is issued in accordance with Article 95(4) of Regulation (EU) 2024/3110, on the basis of

EAD 130186-00-0603 for Three-dimensional nailing plates

This ETA replaces

ETA 25/0618 of 28/07/2025

Translations of this European Technical Assessment in other languages shall fully correspond to the original issued document and should be identified as such.

Communication of this European Technical Assessment, including transmission by electronic means, shall be in full. However, partial reproduction may be made, with the written consent of the issuing Technical Assessment Body. Any partial reproduction has to be identified as such.

II Specific Part

1 Technical description of the product

The angle brackets covered by this ETA are stated in Table A2.1 of Annex 2.

VMG Technics Angle Brackets are one-piece non-welded three-dimensional nailing plates to be used in timber-to-timber or timber-to-concrete connections. The angle brackets are connected to the timber members by anchor nails or screws.

The VMG Technics Angle Brackets are made from pre-galvanized steel DX51D+Z275 or S250GD+275Z according to EN 10346:2015. The yield strength R_{el} or R_{02} of the steel is at least 250 N/mm², the tensile strength R_m at least 330 N/mm² and elongation at failure A_{80} at least 19 %. Amount of the zinc coating is at least 275 g/m².

The product drawings are in Annex 1 and the sizes of VMG Technics Angle Brackets are listed in tables of Annex 2. The connectors can also be supplied with an additional coating made of thermosetting polyester resin powder paint in the following colours: Anthracite Grey (additional code AG at the end of article number), Chocolate Brown (code CB) and Jet Black (code JB).

The steel material thickness of the connectors is $2,00 \pm 0,15$ mm, $2,50 \pm 0,17$ mm or $3,00 \pm 0,20$ mm. The tolerance of the length of the flange is $\pm 2,0$ mm and the tolerance for the other main dimensions of the connectors and position of the holes is $\pm 1,0$ mm. Tolerance for the diameter of fastener holes is within $\pm 0,4$ mm.

Assessment

The manufacturer delivered technical specification of the product that corresponds to the scope of EAD 130186-00-0603.

Conclusion

Requirements set in clause 1.1 of EAD 130186-00-0603 are met.

2 Specification of the intended uses in accordance with the applicable European Assessment Document (hereinafter EAD)

2.1 Intended uses

Intended use of VMG Technics Angle Brackets are timber constructions, where both flanges of the bracket are fixed to strength graded timber according to EN 14081-1, glulam according to EN 14080, softwood- or laminated logs, laminated veneer lumber (LVL) according to EN 14374, plywood according to EN 13986, cross laminated timber (CLT) with edge glued lamellas, or corresponding timber material. The characteristic density ρ_k of the timber shall not be greater than 500 kg/m³. This ETA does not cover angle brackets fixed in the end of a timber member or in the edge of a LVL member.

The forces to be transferred by the angle bracket shall act at the centre of the fastener group on the plane defined by flange A. For non-symmetric connections the flange A means the bigger flange. For unclear cases the flange A is presented in figures of Appendix 1. Shear capacity represents the force component that is in effect in direction of a flange surface. Tensile and compression force are the force components that are in effect in direction perpendicular to a flange surface. The obtuse-angled Angle Bracket 135° connectors 7055AB320, 9065AB320 and 9065AB325 may be loaded only by a shear force parallel to the bent edge of the connector.

VMG Technics Angle Brackets shall be fixed to timber by anchor nails or anchor screws (see Figure 1) according to EN 14592. The diameter of the anchor nails shall be $d = 4,0$ mm and the profiled length at least 24 mm. The anchor screw shall have a conical head, the diameter of the smooth part of the screw shall be $d = 4,5...5,0$ mm and the inner diameter of the threaded part $d_1 \geq 3,0$ mm. The length of the threaded part of the screw shall be at least $6d$.

Connections with VMG Technics Angle Brackets shall fulfil the minimum spacing and edge distance requirement specified in EN 1995-1-1. Timber parts shall not be pre-drilled for the nails or screws. Fasteners shall be perpendicular to the grain of the timber.

The flange B of the Angle Bracket may be connected also to other applicable rigid material such as concrete or steel (support side material). In this case, the angle bracket shall be fixed with CE-marked bolts, threaded bars, anchor bolts or concrete screws with diameter 8/10 mm through the 8,5/11 mm holes to the rigid material. The concrete screws shall have been ETA assessed in accordance with EAD 330232-00-0601 or EAD 330499-01-0601.

For VMG Technics Angle Brackets made of hot-dip zinc coated steel, the intended service classes according to EN 1995-1-1 are classes 1 and 2. In service class 2, the nails or screws shall have an electroplated zinc coating according to EN ISO 2081 at least of type and thickness Fe/Zn 12c, or they shall be hot dip zinc coated according to EN ISO 1461, thickness at least 39 μm .



Figure 1. Fasteners: a) anchor nail and b) anchor screw.

2.2 Working life

The provisions made in this European Technical Approval are based on an assumed intended working life of the angle brackets of 50 years.¹ These provisions are based upon the current state of the art and available knowledge and experience. The indications given as to the working life of the construction product cannot be interpreted as a guarantee, neither given by the product manufacturer or by the Technical Assessment Body, but are regarded only as a means for expressing the expected economically reasonable working life of the product.

2.3 Identification

VMG Technics Angle Brackets are identified by product labels that are marked with "VMGT" logo.

¹ The real working life of a product incorporated in a specific works depends on the environmental conditions to which that works are subject, as well as on the particular conditions of design, execution, use, and maintenance of that works. Therefore, it cannot be excluded that in certain cases the real working life of the product may also be shorter than the assumed working life.

Assessment

Information was given by the manufacturer regarding intended uses of the product.

Working life corresponds to clause 1.2.2 of EAD 130186-00-0603.

Conclusion

Requirements set in clauses 1.2.1 and 1.2.2 of EAD 130186-00-0603 are met.

3 Performance of the product and references to the methods used for its assessment

Table 1 shows how the performance of VMG Technics Angle Brackets is assessed in relation to the essential characteristics.

Table 1. Basic requirements for construction works and essential characteristics

| Basic requirement and essential characteristics | Performance |
|---|-------------------------|
| BWR 1. Mechanical resistance and stability | |
| Joint strength | Clause 3.1 |
| Joint stiffness | No performance assessed |
| Joint ductility | No performance assessed |
| Resistance to seismic actions | No performance assessed |
| Resistance to corrosion and deterioration | Clause 3.1 |
| BWR 2. Safety in case of fire | |
| Reaction to fire | Clause 3.2 |
| Resistance to fire | No performance assessed |

3.1 Mechanical resistance and stability (BWR 1)

3.1.1 Joint strength

Characteristic resistance values of VMG Technics Angle Brackets are given in Annex 2.

Assessment

Behaviour of the joints is ductile as defined in EAD 130186-00-0603, clause 2.2.1.1.1; therefore, mechanical resistances are determined by calculation. Eurofins Expert Services Oy / Ari Kevarinmäki has developed design instructions for VMG Technics Angle Brackets as described in reports EUFI29-25002319-T1 and EUFI29-26000748-T2.

The verification method by calculation has been used so that the ETA gives characteristic values for the nailing plates together with the equations for the calculation of design values.

No quantified performance is determined for ductility.

Conclusion

Calculations have been carried out according to the requirements in EAD 130186-00-0603. Results of the assessment are given in the ETA.

Requirements set in clause 2.2.1 of EAD 130186-00-0603 are met.

3.1.2 Resistance to corrosion and deterioration

VMG Technics Angle Brackets have been assessed as having satisfactory durability and serviceability when used in timber structures when the timber species (including timbers preserved with organic solvent, boron diffusion and related preservatives) described in Eurocode 5 (EN 1995-1-1: 2004) are used and the structures are subject to the dry, internal conditions defined by service classes 1 and 2.

Assessment

The product specification (including associated ancillary components) has been examined and an assessment or appropriate test and evaluation shall be carried out, to determine the thickness of corrosion protection or the material specification.

Conclusion

Assessment is based on the materials' specification.

Requirements set in clause 2.2.3 of EAD 130186-00-0603 are met.

3.2 Safety in case of fire (BWR 2)

3.2.1 Reaction to fire

VMG Technics Angle Brackets are made of materials classified to have reaction to fire class A1 according to EN 13501-1.

Assessment

The three-dimensional nailing plates are considered to satisfy the requirements for performance class A1 of the characteristic reaction to fire, in accordance with the provisions of EC decision 96/603/EC (as amended) without the need for testing on the basis of the listing of their materials in that decision.

Conclusion

Requirements set in clause 2.2.5 of EAD 130186-00-0603 are met.

Overall conclusion

Assessment has been conducted in accordance with EAD 130186-00-0603.

4 Assessment and verification of constancy of performance (hereinafter AVCP) system applied, with reference to its legal base

For the products covered by EAD 130186-00-0603 the applicable European legal act is: Decision 1997/638/EC.

The system to be applied is 2+.

5 Technical details necessary for the implementation of the AVCP system, as provided for in the applicable EAD.

Technical details necessary for the implementation of the AVCP system are laid down in the control plan deposited at Eurofins Expert Services Oy.

Documentation

Test reports presented by the manufacturer and other material used as basis for the assessment are presented in Annex 3.

Documents available to the notified body responsible for the evaluation of constancy of performance (AVCP) include:

- The ETA
- Basic manufacturing process
- Product and materials specifications
- Control plan

Issued in Espoo on 30.06.2026
by Eurofins Expert Services Oy



Katja Vahtikari
Manager

Ari Kevarinmäki
Leading Expert

ANNEX 1: Product details and definitions

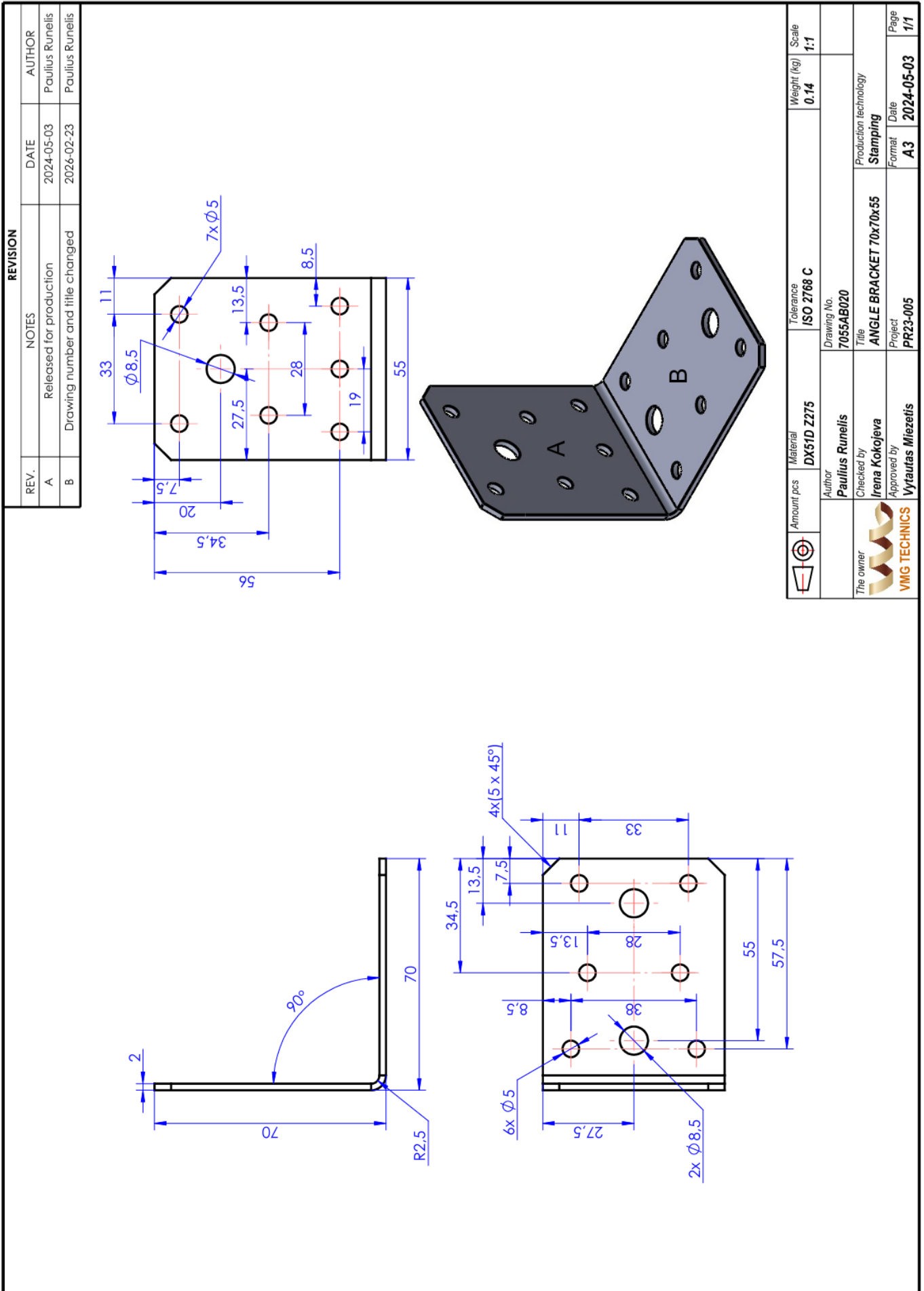

| | | | | | |
|--|-------------------|-----------------------|------------|-------------|-------|
| | Amount pcs | Material | Tolerance | Weight (kg) | Scale |
| | | DX51D Z275 | ISO 2768 C | 0.14 | 1:1 |
| | Author | Drawing No. | | | |
| | Paulius Runelis | 7055AB020 | | | |
| | Checked by | Production technology | | | |
| | Irena Kokojeva | Stamping | | | |
| | Approved by | Format | | | |
| | Vytautas Miezetis | A3 | | | |
| | | Date | | | |
| | | 2024-05-03 | | | |
| | | Page | | | |
| | | 1/1 | | | |

ANNEX 1: Product details and definitions

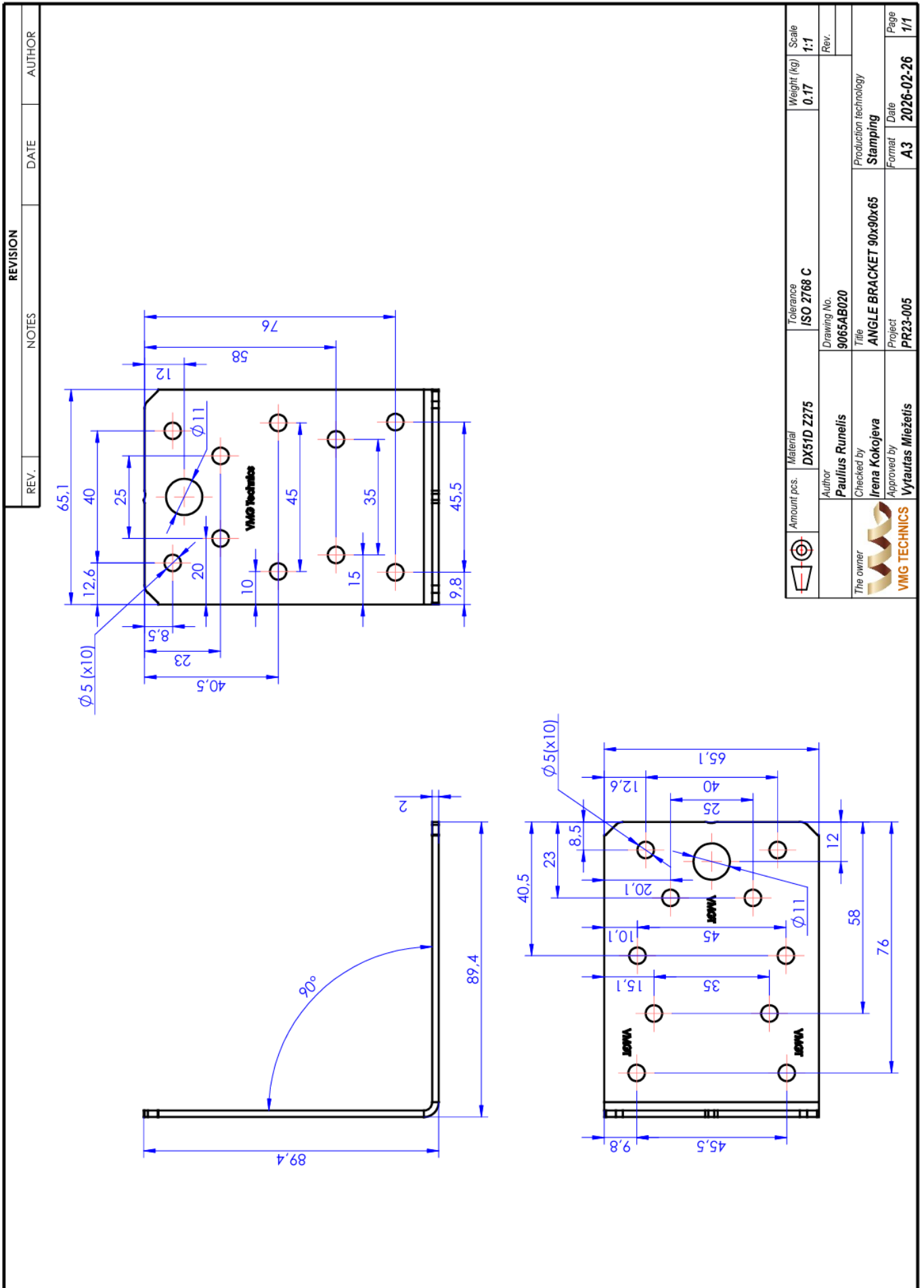

ANNEX 1: Product details and definitions

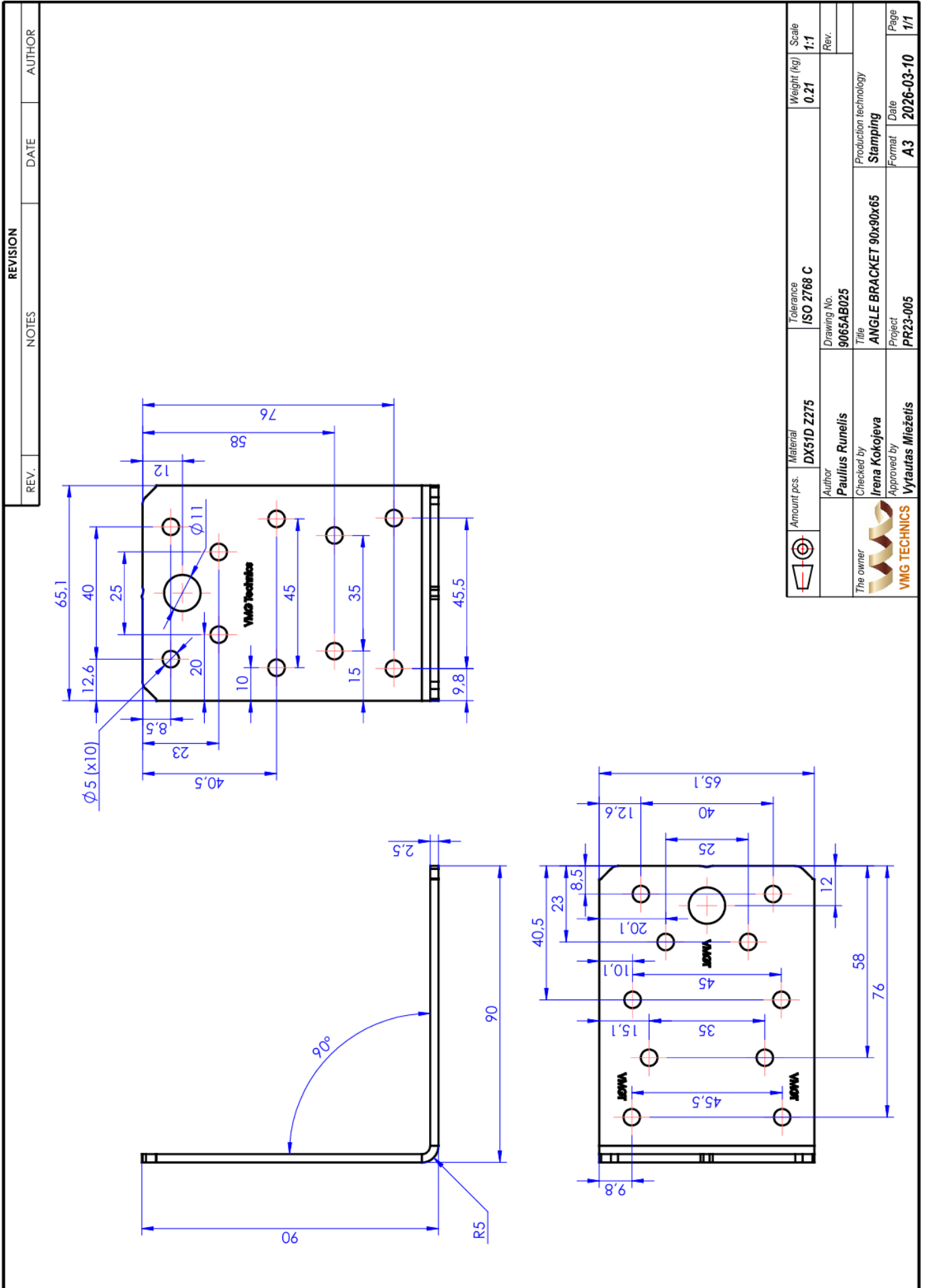

ANNEX 1: Product details and definitions

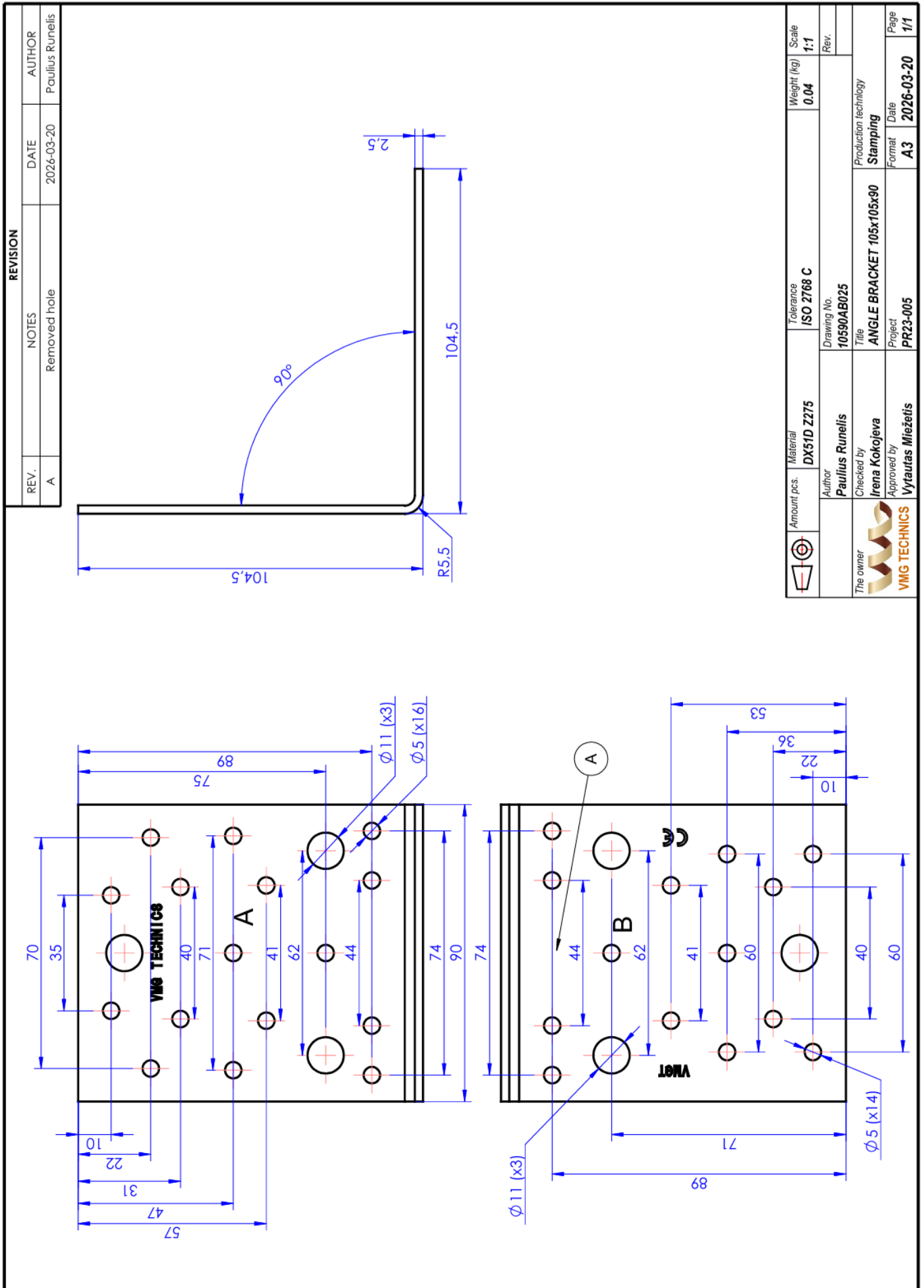

ANNEX 1: Product details and definitions

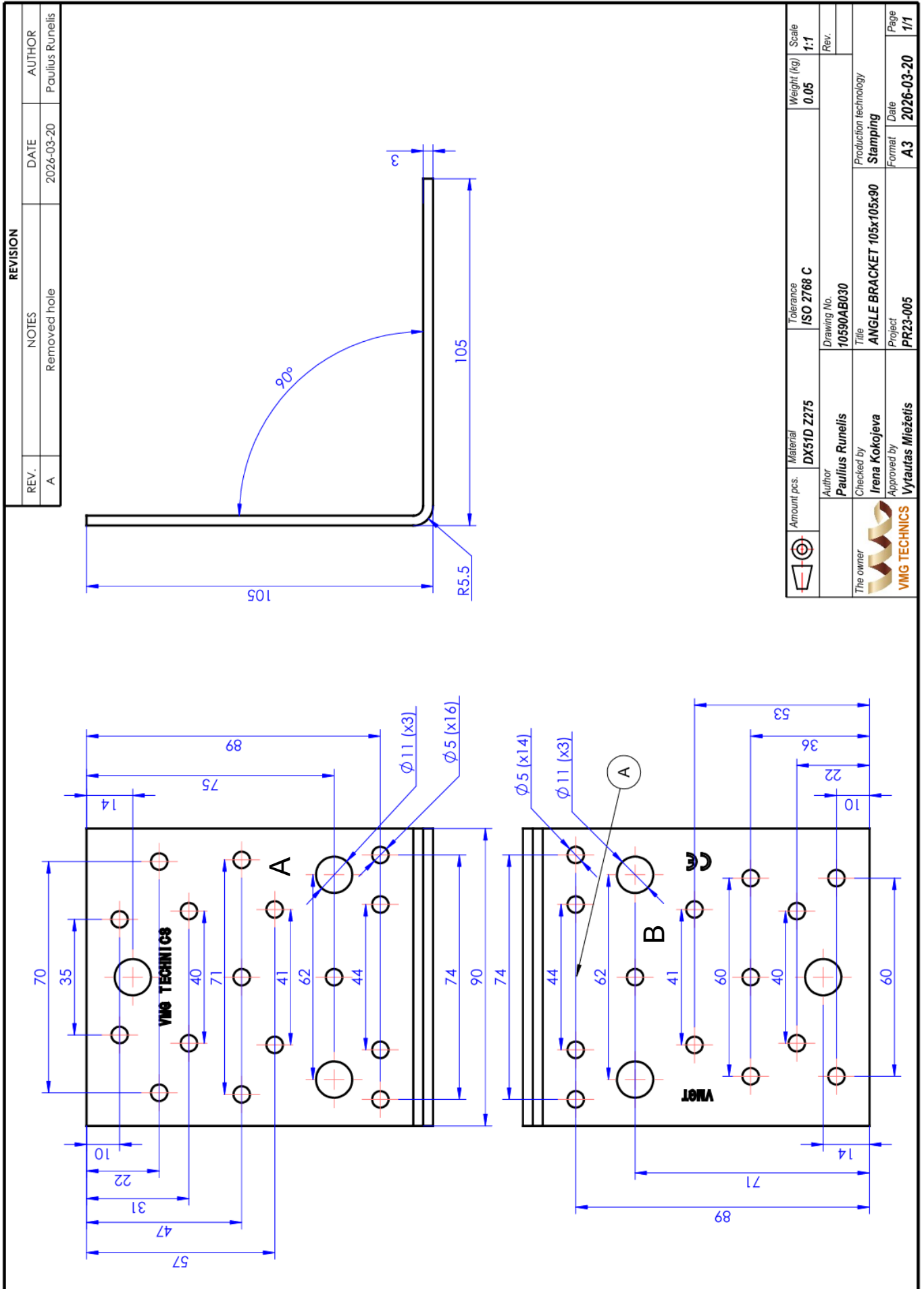

ANNEX 1: Product details and definitions

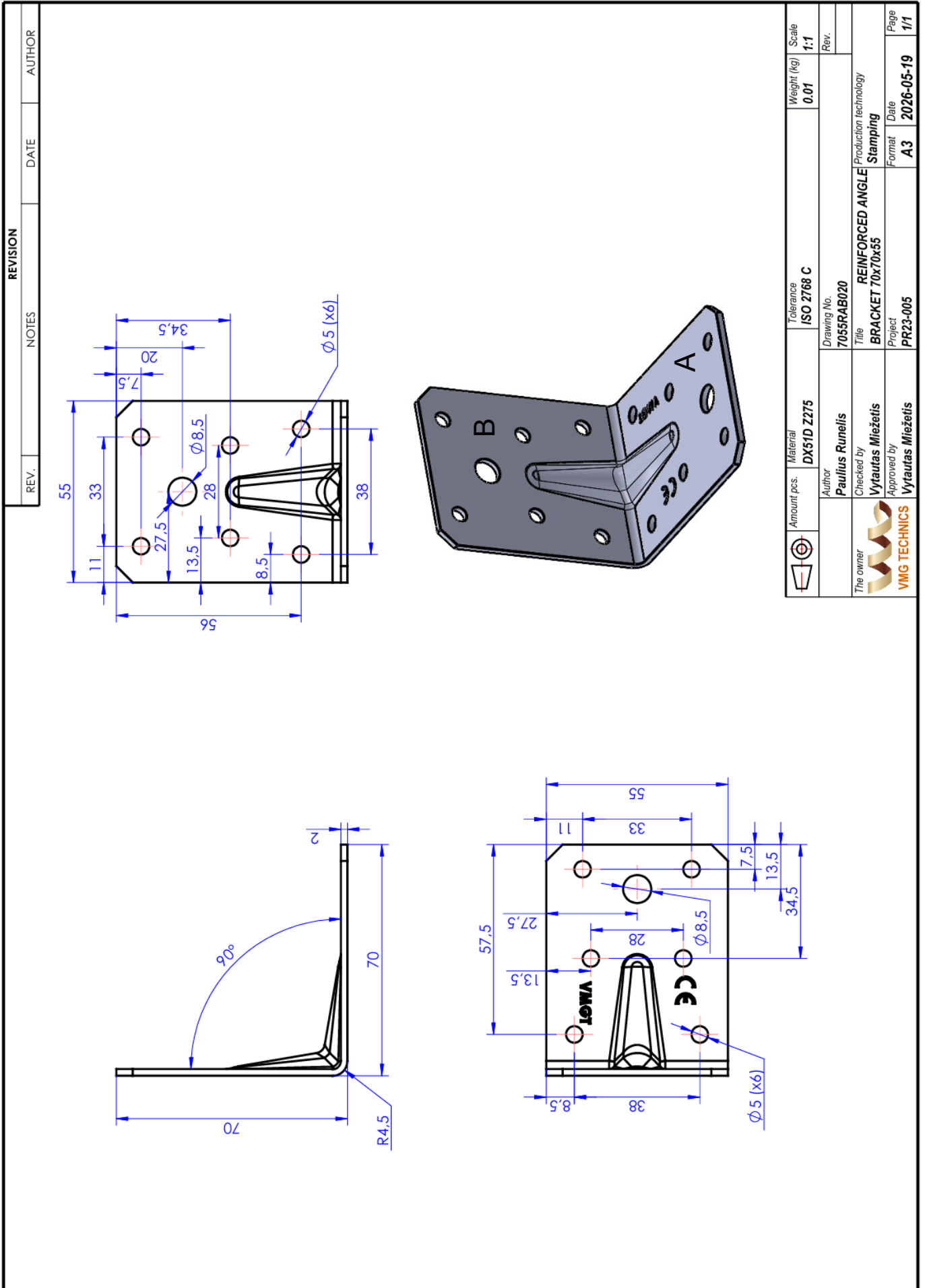

ANNEX 1: Product details and definitions

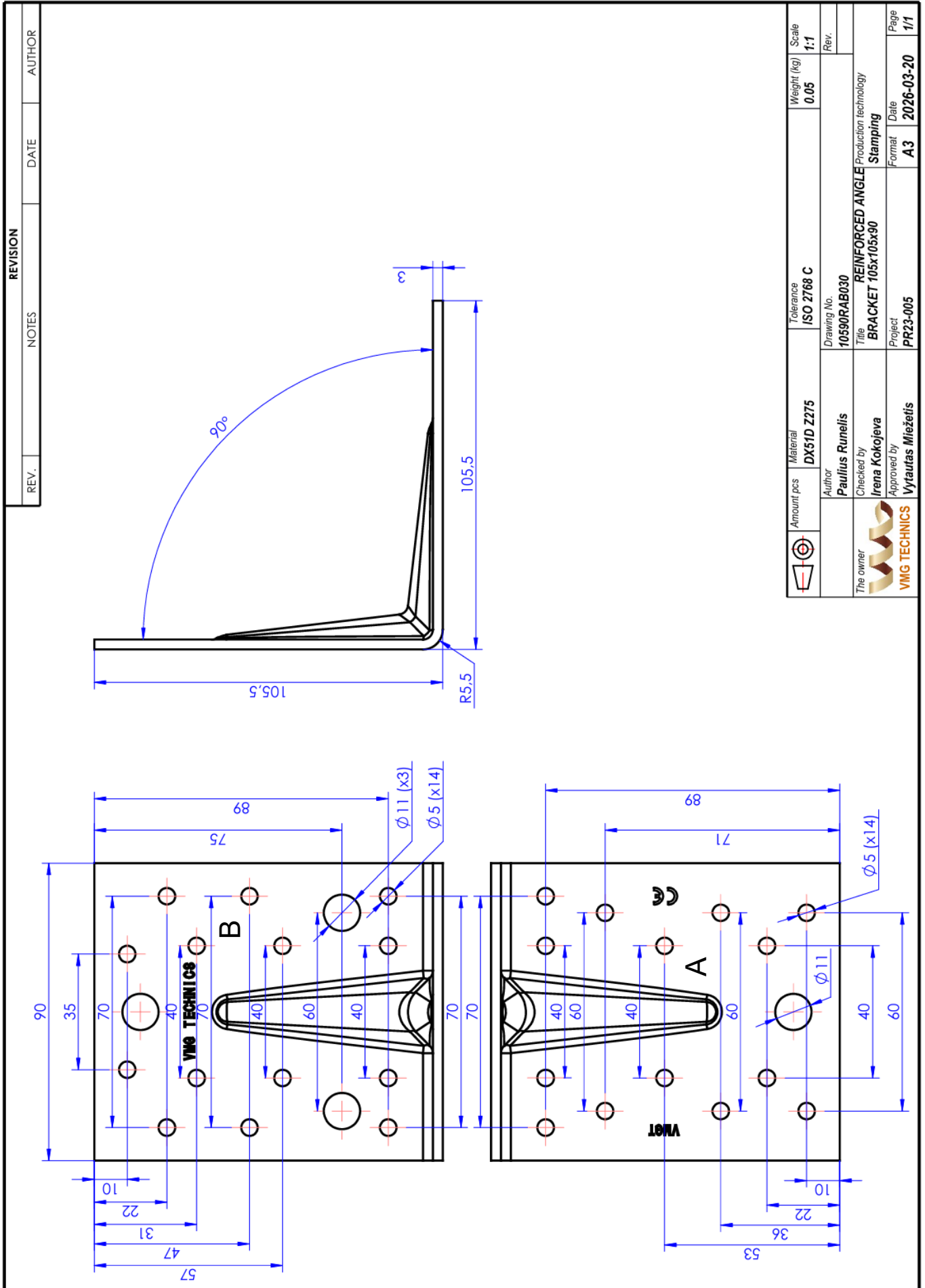

| REV. | NOTES | DATE | AUTHOR |
|------|-------|------|--------|
| | | | |

| | | | | |
|---------------|---|---|--|---------------------------|
| | Material DX51D Z275 | Tolerance ISO 2768 C | Weight (kg) 0.05 | Scale 1:1 |
| | Author Paulius Runelis | Drawing No. 10590RAB030 | Production technology | |
| | Checked by Irena Kokojeva | Title REINFORCED ANGLE BRACKET 105x105x90 | Production technology Stamping | |
| | Approved by Vytautas Miežetis | Project PR23-005 | Format A3 | Date 2026-03-20 |
| The owner | | | | Page 1/1 |

ANNEX 1: Product details and definitions

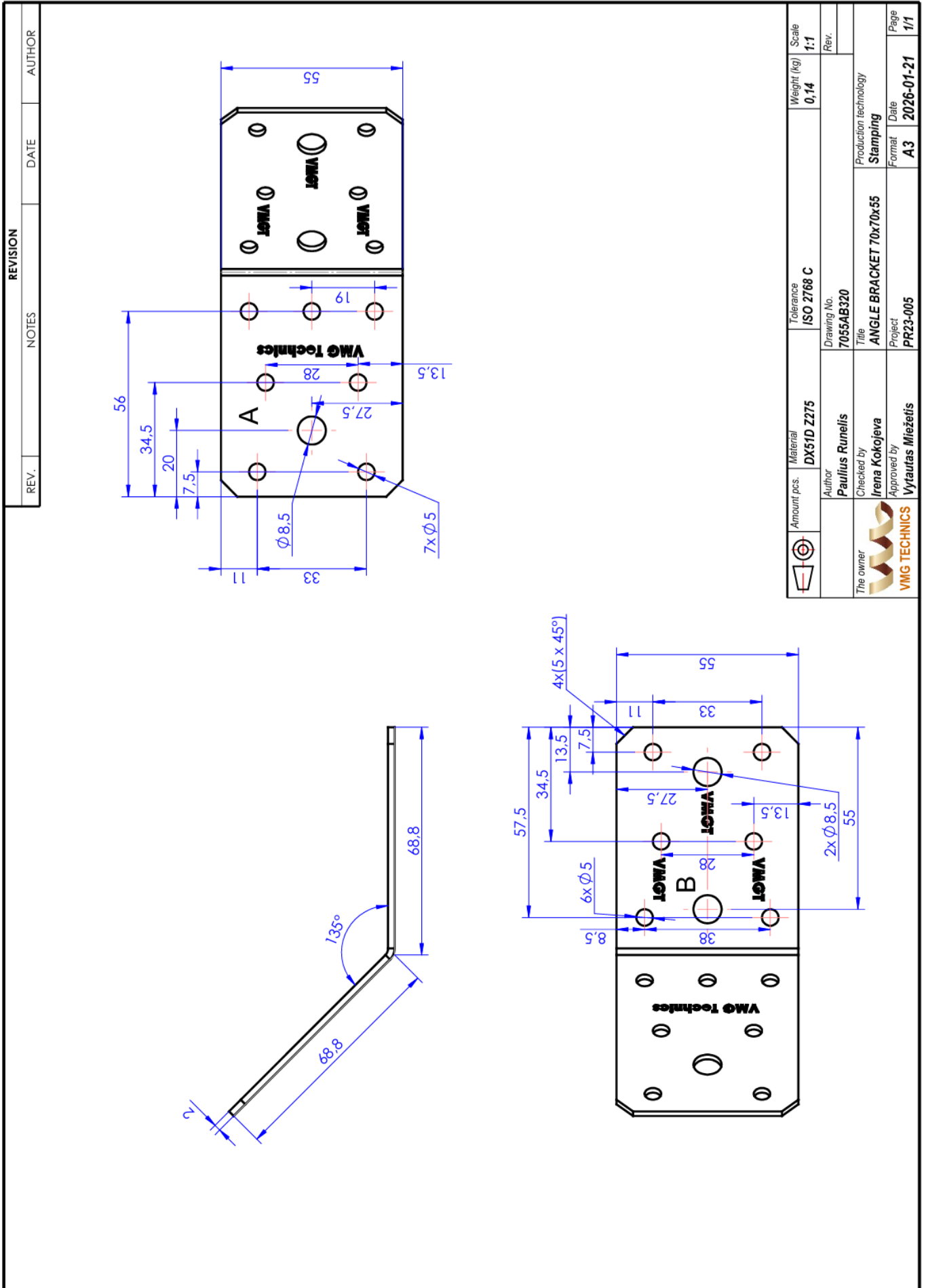

ANNEX 1: Product details and definitions

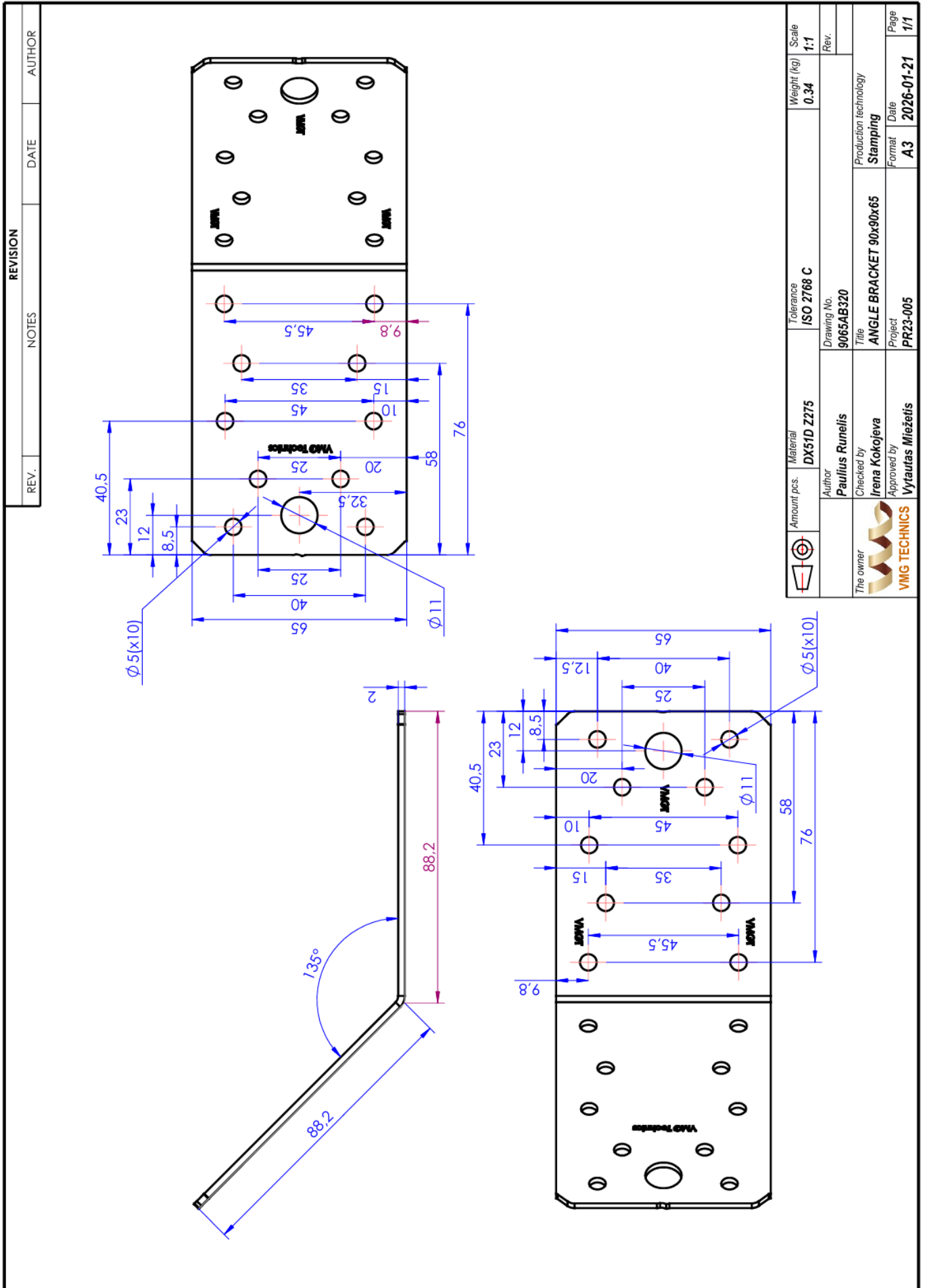

| | | | | | |
|--|-------------------|------------------------|-----------------------|-------------|-------|
| | Amount pcs. | Material | Tolerance | Weight (kg) | Scale |
| | | DX51D Z275 | ISO 2768 C | 0.34 | 1:1 |
| | Author | Drawing No. | Rev. | | |
| | Paulius Runelis | 9065AB320 | | | |
| | Checked by | Title | Production technology | | |
| | Irena Kokojeva | ANGLE BRACKET 90x90x65 | Stamping | | |
| | Approved by | Project | Format | Date | Page |
| | Vytautas Miežetis | PR23-005 | A3 | 2026-01-21 | 1/1 |

ANNEX 2. CHARACTERISTIC LOAD-CARRYING CAPACITIES

Characteristic resistances for VMG Technics Angle Brackets - calculation method

Load carrying capacity of angle bracket connections

The design resistance R_d of the angle bracket connection is

$$R_d = k_{\text{mod}} \frac{R_k}{\gamma_M} \quad (1)$$

where k_{mod} is the modification factor according to EN 1995-1-1 taking into account the effect of the duration of the load and moisture content for timber, γ_M is the partial factor for the resistance of connections according to the relevant National annex of EN 1995-1-1 and R_k is the characteristic resistance of the angle bracket connection.

When the connection made by the angle bracket is loaded by a shear force at the plane of flange A in the middle of the flange, it shall be checked that the conditions according to equations (2) to (4) are fulfilled

$$F_d \leq R_{A,d} \quad (2)$$

$$F_{x,d} \leq R_{B,x,d} \quad (3)$$

$$F_{z,d} \leq \begin{cases} R_{B,z,t,d} & \text{when the connection is in tension} \\ R_{B,z,c,d} & \text{when the connection is in compression} \end{cases} \quad (4)$$

where $F_{x,d}$ is the component in the direction of the bent edge of the angle bracket from the connection force F_d and $F_{z,d}$ is the component perpendicular to $F_{x,d}$ from the connection force F_d . The obtuse-angled Angle Bracket 135° connectors 7055AB320, 9065AB320 and 9065AB325 may be loaded only by a shear force parallel to the bent edge: $F_d = F_{x,d}$.

In addition, when the connection is loaded in tension, the following interaction equation shall be fulfilled:

$$\left(\frac{F_{z,d}}{R_{B,z,t,d}} \right)^2 + \left(\frac{F_{x,d}}{R_{B,x,d}} \right)^2 \leq 1 \quad (5)$$

Characteristic resistance

$$R_{A,k} = n_A F_{A,v,Rk} \quad (6)$$

where n_A is number of fasteners at flange A. $F_{A,v,Rk}$ is the characteristic lateral load-carrying capacity of the fastener in the timber part against flange A according to EN 1995-1-1, equation (7) for steel plate thickness t less than or equal to $d/2$ and (8) for thicker steel plates of thickness greater than or equal to d :

$$F_{v,Rk} = \min \begin{cases} 0,4 f_{h,k} t_1 d & \text{(a)} \\ 1,15 \sqrt{2 M_{y,Rk} f_{h,k} d} + \frac{F_{ax,Rk}}{4} & \text{(b)} \end{cases} \quad (7)$$

$$F_{v,Rk} = \min \begin{cases} f_{h,k} t_1 d & \text{(a)} \\ f_{h,k} t_1 d \left[\sqrt{2 + \frac{4M_{y,Rk}}{f_{h,k} d t_1^2}} - 1 \right] + \frac{F_{ax,Rk}}{4} & \text{(b)} \\ 2,3 \sqrt{M_{y,Rk} f_{h,k} d} + \frac{F_{ax,Rk}}{4} & \text{(c)} \end{cases} \quad (8)$$

where $t_1 = L - t$ when L is the length of the fastener, t is the thickness of steel plate, $M_{y,k}$ is according to standards EN 14592 and EN 409 experimentally determined characteristic value of the yield moment of the fastener, $F_{ax,Rk}$ is the withdrawal resistance of the fastener according to Eq. (10) limited at maximum to $1/3$ with nails and $1/2$ with screws from the load-carrying capacity $F_{v,Rk}$ and the characteristic value of the embedding strength

$$f_{h,k} = 0,082 \rho_k d^{-0,3} \quad \text{N/mm}^2 \quad (9)$$

The characteristic withdrawal resistance of the nail

$$F_{ax,Rk} = f_{ax,k} d t_{pen} \leq f_{tens,k} \quad (10a)$$

and for the screw

$$F_{ax,Rk} = n^{-0,1} f_{ax,k} d l_{ef} \left(\frac{\rho_k}{\rho_a} \right)^{0,8} \leq n^{-0,1} f_{tens,k} \quad (10b)$$

where $f_{ax,k}$ is the withdrawal parameter determined by testing according to standards EN 14592 and EN 1382 for the actual timber material with density ρ_a , $f_{tens,k}$ is the experimentally determined tensile resistance of the fastener together with a steel plate, t_{pen} is the penetration depth of the profiled part of the nail in timber, n is the number of the screws in the flange of connector, l_{ef} is the length of threaded part of the screw and ρ_k is the characteristic density of timber in the actual connection. If the penetration depth for an anchor nail is less than $t_{pen} \leq 8d = 32$ mm, the resistance according to Eq. (10a) is reduced by $(t_{pen}/8\text{mm} - 3)$.

Eq. (8) may be used for angular ring shank nails, if the nominal thickness of steel plate is at least 2,00 mm, the length of the conical part of nail head is at least 4 mm and the diameter of the cone at the head of the nail is at least 5,2 mm. Otherwise linear interpolation of equations (7) and (8) is used for the steel plate thicknesses between 2 and 4 mm.

Characteristic resistance

$$R_{B,x,k} = k_m F_{B,v,Rk} \quad (11)$$

where $F_{B,v,Rk}$ is the characteristic lateral load-carrying capacity of the fastener in the timber part against flange B, according to EN 1995-1-1, and the factor k_m depends on the placement of the fasteners. Values of k_m are given in Table A2.1 for cases, where fasteners are used in all 5 mm holes of the angle bracket.

Characteristic tension resistance for Angle Brackets without reinforcement ribs

$$R_{B,z,t,k} = \min \begin{cases} F_{n,1} + F_{n,2} - 3 \cdot \frac{F_{n,1} \cdot d_1 + F_{n,2} \cdot d_2 - \frac{B \cdot t_d^2}{4} \cdot f_y}{2L_B + d_2} & \text{(a)} \\ \frac{t_d^2 f_y}{4 d_1} \cdot (B + B_{net,1}) & \text{(b)} \\ \frac{t_d^2 f_y}{4 d_2} \cdot (B + B_{net,2}) + \frac{F_{n,1} (d_2 - d_1)}{d_2} & \text{(c)} \\ F_{n,1} + F_{n,2} & \text{(d)} \end{cases} \quad (12)$$

where

- d_1 distance between the bent edge and the hole row nearest to it in flange B ($i = 1$),
- d_2 distance between the bent edge and the hole row second nearest to it in flange B ($i = 2$),
- B the width of the Angle Bracket,
- t_d is the thickness of the Angle Bracket to be used in calculations (= the minimum thickness minus the thickness of the zinc coating),
- f_y yield strength of the steel of the Angle Bracket,
- L_B the length of flange B from the middle of the bent edge,
- $B_{net,i}$ the net width of the Angle Bracket at hole row i and

$$F_{n,i} = n_i F_{ax,Rk} \quad (13)$$

when n_i is the number of fasteners at row i and $F_{ax,Rk}$ is the characteristic withdrawal resistance of the fastener in the timber member against flange B according to EN 1995-1-1.

If there are fasteners only in one or two rows at flange B, in expression (12) equation (a) is inserted by $F_{n,2} = 0$ and $d_2 = d_1$ and equation (c) needs not to be checked.

Characteristic tension resistance for an Angle Bracket with reinforcement rib

$$R_{B,z,t,k} = \min \left\{ \begin{array}{l} \Sigma F_{a,j} + F_{n,1} - 3 \cdot \frac{F_{n,1} \cdot d_1 - \frac{B \cdot t_d^2}{4} \cdot f_y}{2L_B - 2a + d_2} \quad (a) \\ \max \left\{ \begin{array}{l} \frac{t_d^2 f_y}{4(a + d_1)} \cdot (B + B_{net,1}) + \frac{\Sigma(F_{a,j}(a + d_1 - a_j))}{a + d_1} \quad (b) \\ \Sigma F_{a,j} + F_{n,1} \quad (c) \end{array} \right. \end{array} \right. \quad (14)$$

where

- d_1 distance between the end of the reinforcement fold and the hole row nearest to it in flange B ($i = 1$)
- a is the length of the stiffener ridge in flange B
- a_j is distance between bent edge and the fastener row j
- B the width of the Angle Bracket at the end of reinforcement rib
- t_d is the thickness of the connector to be used in calculations (= the minimum thickness minus the thickness of the zinc coating)
- f_y yield strength of the steel of the connector
- L_B the length of flange B from the middle of the bent edge
- $B_{net,i}$ the net width of the Angle Bracket at hole row i

$$F_{n,i} = n_i F_{ax,Rk} \quad (15)$$

$$F_{a,j} = n_j F_{ax,Rk} \quad (16)$$

when n_1 is the number of fasteners in the row nearest to the end of the reinforcement fold (i), n_j is the number of fasteners at row j in the part of flange B with the reinforcement and $F_{ax,Rk}$ is the characteristic withdrawal resistance of the fastener in the timber member against flange B according to EN 1995-1-1.

If the flange B of the connector only has one row of fasteners on the part without stiffener rib, in equation (14) is inserted $F_{n,1} = 0$.

For a stiffened connector that have no fasteners on the reinforcement area, the tension capacity may be calculated as maximum of equations (12) and (14). Then in expression (12), the flange length L_B is taken as distance between the end of the reinforcement rib and the end of the flange.

Characteristic compression resistance for Angle Brackets without reinforcement

$$R_{B,z,c,k} = t_d \cdot \sqrt{3 \cdot B \cdot B_{\text{net}} \cdot f_y \cdot f_{c,90,k}} \quad (17)$$

where t_d , B and f_y are defined as for equation (12) and B_{net} is the smallest net width of the flange B and $f_{c,90,k}$ is the characteristic compression strength perpendicular to the timber member against flange B.

Characteristic compression resistance for Angle Brackets with reinforcements

$$R_{z,c,B,k} = 3 \cdot a \cdot B_{\text{ef}} \cdot f_{c,90,k} + t_d \cdot \sqrt{3 \cdot B \cdot B_{\text{net}} \cdot f_y \cdot f_{c,90,k}} \quad (18)$$

where a is the length of the reinforcement rib from the bent edge of the Angle Bracket, B_{ef} is the width of the Angle Bracket minus the width of the reinforcement and the other symbols as for equation (17).

Calculated characteristic compression resistances of VMG Technics Angle Brackets are shown in Tables A2.2 and A2.3 for connections of sawn timber of strength class C24.

For a timber-to-concrete angle bracket connection, the resistance of the corresponding timber-to-timber connection may be used, provided that the lateral load carrying capacity and axial tension capacity of the fastener group of flange B in concrete are greater or equal than the capacities of the fastener group of flange B in timber member.

Structural requirements

Connections with the Angle Brackets shall fulfil the minimum spacing and edge and end distance requirements specified in EN 1995-1-1. The minimum distances a_1 and a_2 in table 8.2 of EN 1995-1-1 can be multiplied by a factor of 0,7 (nailed steel-to-timber connections).

If Angle Brackets are placed on both sides of the timber, the point of the fastener shall be at most $4d$ from the surface of the opposing side, where d is the nominal diameter of the fastener.

It is not possible to fill all holes by fasteners in all configurations and loading combinations of the Angle Brackets. In partial fixing, the fasteners shall always be placed in the row nearest to the end of the flange and as near as possible to the bent edge of the Angle Bracket. In addition, the fasteners should be positioned symmetrically.

All fasteners in same flange shall be identical. The opposing flanges may have different fasteners.

Table A2.1. Article numbers of the VMG Technics Angle Brackets, nominal dimensions, grade of steel plate, number of fasteners in flange B n_B , eccentricity of the fastener group e , the sum of the moment arms for the fastener group Σr_i and values for factor k_m when the fasteners are used in all 5 mm diameter of holes.

| Art. No. | Size (mm) | Grade | n_B | e (mm) | Σr_i (mm) | k_m |
|-------------|----------------|-------|-------|----------|-------------------|-------|
| 7055AB020 | 70x70x55x2,0 | DX51D | 6 | 35,8 | 150,9 | 2,612 |
| 9065AB020 | 89x89x65x2,0 | DX51D | 10 | 47,2 | 297,5 | 4,025 |
| 9065AB025 | 90x90x65x2,5 | DX51D | 10 | 47,6 | 297,5 | 4,006 |
| 10590AB020 | 104x104x90x2,0 | DX51D | 14 | 52,6 | 508,8 | 5,718 |
| 10590AB025 | 105x105x90x2,5 | DX51D | 14 | 52,9 | 508,8 | 5,702 |
| 10590AB030 | 105x105x90x3,0 | DX51D | 14 | 53,1 | 508,8 | 5,686 |
| 7055RAB020 | 70x70x55x2,0 | DX51D | 6 | 36,3 | 148,6 | 2,576 |
| 9065RAB020 | 90x90x65x2,0 | DX51D | 10 | 47,8 | 295,2 | 3,957 |
| 9065RAB025 | 90x90x65x2,5 | DX51D | 10 | 47,6 | 295,2 | 3,970 |
| 10590RAB020 | 105x105x90x2,0 | DX51D | 14 | 54,7 | 536,8 | 5,924 |
| 10590RAB025 | 105x105x90x2,5 | DX51D | 14 | 54,5 | 536,8 | 5,940 |
| 10590RAB030 | 106x106x90x3,0 | DX51D | 14 | 54,7 | 536,8 | 5,924 |
| 7055AB320 | 69x69x55x2,0 | DX51D | 6 | 34,9 | 150,9 | 2,652 |
| 9065AB320 | 88x88x65x2,0 | DX51D | 10 | 80,2 | 297,5 | 2,796 |
| 9065AB325 | 88x88x65x2,5 | DX51D | 10 | 80,4 | 297,5 | 2,792 |

Table A2.2. Characteristic compression resistance $R_{B,z,c,k}$ for unreinforced VMG Technics Angle Brackets used with sawn timber in strength class C24. For compression capacities with other strength classes, the characteristic resistance $R_{B,z,c,k}$ should be multiplied by the factor $\sqrt{f_{c,90,k}}/2,5$, where $f_{c,90,k}$ is the characteristic compression strength perpendicular to the grain of the actual timber grade in N/mm².

| Art. No. | Size (mm) | f_y (N/mm ²) | t_d (mm) | B (mm) | B_{net} (mm) | $R_{B,z,c,k}$ (kN) |
|------------|----------------|-------------------------------|------------|----------|----------------|--------------------|
| 7055AB020 | 70x70x55x2,0 | 250 | 1,81 | 55 | 37 | 3,54 |
| 9065AB020 | 89x89x65x2,0 | 250 | 1,81 | 65 | 46 | 4,29 |
| 9065AB025 | 90x90x65x2,5 | 250 | 2,29 | 65 | 46 | 5,42 |
| 10590AB020 | 104x104x90x2,0 | 250 | 1,81 | 90 | 63 | 5,90 |
| 10590AB025 | 105x105x90x2,5 | 250 | 2,29 | 90 | 63 | 7,47 |
| 10590AB030 | 105x105x90x3,0 | 250 | 2,76 | 90 | 63 | 9,00 |

Table A2.3. Characteristic compression resistance $R_{B,z,c,k}$ for reinforced VMG Technics Angle Brackets used with sawn timber in strength class C24. For compression capacities with other strength classes, the characteristic resistance $R_{B,z,c,k}$ should be multiplied by the factor $\sqrt{f_{c,90,k}}/2,5$, where $f_{c,90,k}$ is the characteristic compression strength perpendicular to the grain of the actual timber grade.

| Art. No. | Size (mm) | f_y (N/mm ²) | t_d (mm) | B (mm) | a (mm) | B_{ef} (mm) | B_{net} (mm) | $R_{B,z,c,k}$ (kN) |
|-------------|----------------|-------------------------------|------------|----------|----------|---------------|----------------|--------------------|
| 7065RAB020 | 70x70x55x2,0 | 250 | 1,81 | 55 | 34 | 39 | 45 | 13,8 |
| 9065RAB020 | 90x90x65x2,0 | 250 | 1,81 | 65 | 48 | 46 | 45 | 20,8 |
| 9065RAB025 | 90x90x90x2,5 | 250 | 2,29 | 65 | 48 | 46 | 45 | 21,9 |
| 10590RAB020 | 105x105x90x2,0 | 250 | 1,81 | 90 | 67 | 65 | 72 | 39,0 |
| 10590RAB025 | 105x105x90x2,5 | 250 | 2,29 | 90 | 67 | 65 | 72 | 40,6 |
| 10590RAB030 | 106x106x90x3,0 | 250 | 2,76 | 90 | 67 | 65 | 72 | 42,3 |

Table A2.4. Characteristic tension resistance $R_{B,z,t,k}$ for unreinforced VMG Technics Angle Bracket connections when anchor nails 4x50, $f_{ax,k} = 6$ N/mm² and $t_{pen} = 34$ mm, are used in all holes.

| Art. No. | Size (mm) | L_B (mm) | d_1 (mm) | n_1 | $B_{net,1}$ (mm) | $F_{n,1}$ (N) | d_2 (mm) | n_2 | $B_{net,2}$ (mm) | $F_{n,2}$ (N) | $F_{z,t,k}$ (a) (N) | $F_{z,t,k}$ (b) (N) | $F_{z,t,k}$ (c) (N) | $F_{z,t,k}$ (d) (N) | $R_{B,z,t,k}$ (kN) |
|------------|----------------|------------|------------|-------|------------------|---------------|------------|-------|------------------|---------------|---------------------|---------------------|---------------------|---------------------|--------------------|
| 7055AB020 | 70x70x55x2,0 | 69 | 13.0 | 2 | 37 | 1632 | 34.5 | 2 | 45 | 1632 | 2112 | 1449 | 1611 | 3264 | 1.45 |
| 9065AB020 | 89x89x65x2,0 | 88 | 12.4 | 2 | 55 | 1632 | 30.4 | 2 | 55 | 1632 | 2442 | 1982 | 1775 | 3264 | 1.77 |
| 9065AB025 | 90x90x65x2,5 | 89 | 12.8 | 2 | 55 | 1632 | 30.8 | 2 | 55 | 1632 | 2548 | 3073 | 2231 | 3264 | 2.23 |
| 10590AB020 | 104x104x90x2,0 | 104 | 14.0 | 4 | 70 | 3264 | 32.0 | 1 | 63 | 816 | 3413 | 2340 | 2815 | 4080 | 2.34 |
| 10590AB025 | 105x105x90x2,5 | 105 | 14.3 | 4 | 70 | 3264 | 32.3 | 1 | 63 | 816 | 3541 | 3667 | 3371 | 4080 | 3.37 |
| 10590AB030 | 105x105x90x3,0 | 105 | 14.5 | 4 | 70 | 3264 | 32.5 | 1 | 63 | 816 | 3697 | 5254 | 4049 | 4080 | 3.70 |

Table A2.5. Characteristic tension resistance $R_{B,z,t,k}$ for reinforced VMG Technics Angle Bracket connections when anchor nails 4x50, $f_{ax,k} = 6$ N/mm² and $t_{pen} = 34$ mm, are used in all holes.

Tension resistances according to equation (14):

| Art. No. | Size (mm) | L_B (mm) | a (mm) | a_1 (mm) | n_{a1} | $F_{a,1}$ (N) | a_2 (mm) | n_{a2} | $F_{a,2}$ (N) | a_3 (mm) | n_{a3} | $F_{a,3}$ (N) | d_1 (mm) | n_1 | $B_{net,1}$ (mm) | $F_{n,1}$ (N) | $F_{z,t,k}$ (a) (N) | $F_{z,t,k}$ (b) (N) | $F_{z,t,k}$ (c) (N) | $R_{B,z,t,k}$ (kN) |
|-------------|----------------|------------|----------|------------|----------|---------------|------------|----------|---------------|------------|----------|---------------|------------|-------|------------------|---------------|---------------------|---------------------|---------------------|--------------------|
| 7055RAB020 | 70x70x55x2,0 | 69 | 34 | 13.0 | 2 | 1632 | | | 0 | | | | 0.5 | 2 | 45 | 1632 | 3708 | 1611 | 3264 | 3.26 |
| 9065RAB020 | 90x90x65x2,0 | 89 | 48 | 13.0 | 2 | 1632 | 31.0 | 2 | 1632 | | | | 0.5 | 2 | 55 | 1632 | 5350 | 2290 | 4896 | 4.90 |
| 9065RAB025 | 90x90x65x2,5 | 89 | 48 | 12.8 | 2 | 1632 | 30.8 | 2 | 1632 | | | | 0.3 | 2 | 55 | 1632 | 5655 | 2605 | 4896 | 4.90 |
| 10590RAB020 | 105x105x90x2,0 | 104 | 67 | 15.0 | 4 | 3264 | 47.0 | 2 | 1632 | 57.0 | 2 | 1632 | 6.0 | 2 | 80 | 1632 | 8484 | 4009 | 8160 | 8.16 |
| 10590RAB025 | 105x105x90x2,5 | 104 | 67 | 14.8 | 4 | 3264 | 46.8 | 2 | 1632 | 56.8 | 2 | 1632 | 5.8 | 2 | 80 | 1632 | 8913 | 4307 | 8160 | 8.16 |
| 10590RAB030 | 106x106x90x3,0 | 106 | 67 | 15.0 | 4 | 3264 | 47.0 | 2 | 1632 | 57.0 | 2 | 1632 | 6.0 | 2 | 80 | 1632 | 9341 | 4641 | 8160 | 8.16 |

ANNEX 3

MATERIAL USED AS BASIS FOR THE ASSESSMENT

| Ref. No. | Author or institution | Report No. | Date | Title / Issue |
|----------|-----------------------------|--------------------|-----------|--|
| 1 | Eurofins Expert Services Oy | EUF129-25002319-T1 | 24.6.2025 | Initial testing of VMG Technics Angle Brackets |
| 2 | Eurofins Expert Services Oy | EUF129-26000748-T2 | 27.5.2026 | Initial testing of VMG Technics Angle Brackets |